

Owner's Manual — Phoenix Arctic Max

Installation, Operation and Service Instructions

Read and Save These Instructions

The new Phoenix Arctic Max is the first portable air conditioner designed specifically for the Restoration Industry. The Phoenix Arctic Max boasts one ton (12,000 BTUs) of cooling capacity operating in 95°F and 60% conditions while drawing under 12 amps. In a single pass, this provides a 15 degree temperature drop on the 430 CFM evaporator (cooling) air stream and water removal equivalent to 100 pints per day.

The Phoenix Arctic Max gives the restoration contractor vital temperature control in the affected area to optimize drying efficiency or in unaffected areas to safe-guard occupant comfort. The Phoenix Arctic Max's cooling power also makes it the ideal accessory to pre-treat air to improve the

performance of desiccant or LGR dehumidifiers. When used in conjunction with the Phoenix Solution LGR performance amplifier, the Phoenix Arctic Max provides a reliable cooling air stream to maximize overall performance. The Phoenix Arctic Max features thermostatically controlled cooling to insure maintenance of desired conditions and prevent potential over-cooling.

Set-up and operation is simple using the Phoenix window accessory kit, and a 15 amp outlet. The Phoenix Arctic Max also features filter efficiency options up to MERV-11, an internal condensate pump with 30 foot drain hose and 20 foot power cord. The Phoenix Arctic Max promises years of service and our "proven" performance.

The Phoenix Arctic Max Portable Air Conditioner

- 1 Ton, 12,000 BTUs of Cooling*
- 100 Pints/Day of Water Removal*
- 11.8 Amps*
- Adjustable Thermostat
- Easy Set-up and Operation
- Cooling (Evaporator) Airflow 430 CFM
- Exhaust (Condenser) Airflow 430 CFM
- Multiple Ducting Options
- Multiple Filter Options
- 20 ft. Vertical Lift Condensate Pump
- 30 ft. Drain Hose
- 20 ft. Power Cord (grounded)
- Recessed Wheels
- Legendary Stainless Construction

*95°F/60% RH



Phoenix Arctic Max
PN 4030120

TS-685
01/15

Specifications subject to change without notice.

Table of Contents

Introduction	1
1. Specifications	2
2. Operation	3
2.1 Transporting	3
2.2 Electrical Requirements	3
2.3 Condensate Removal	3
2.4 Ducting.....	3
2.5 Power Switch	3
2.6 Pump Purge Switch	3
2.7 Hour Meter	3
2.8 Thermostat Operation	3
2.9 Defrost Timer.....	3
2.10 Low Pressure Control	4
3. Maintenance	4
3.1 Air Filter	4
3.2 Storage	4
4. Service	4
4.1 Technical description	4
4.2 Troubleshooting	5
4.3 Blower Replacement	5
4.4 Defrost Thermostat and Timer	6
4.5 Condensate Pump	6
4.6 Gravity Drain Option	6
4.7 Relay.....	6
5. Options and Accessories	6
6. Wiring Diagram	7
7. Service Parts	8
8. Warranty	9

Serial No. _____

Purchase Date ____/____/____

Dealer's Name _____

Read the operation and maintenance instructions carefully before using this unit. Proper adherence to these instructions is essential to obtain maximum benefit from your Phoenix Arctic Max dehumidifier.

WARNING

- It is designed to be used **INDOORS ONLY**.
- If used in a wet area, plug it into a **GROUND FAULT INTERRUPTER**.
- **DO NOT** use the Phoenix Arctic Max as a bench or table.
- It must always be used in the upright position.

1 Specifications

Part No.	4030120
Power	11.8 amps@ 95°F/60% RH 12,000 Btu/Hr, 100 ppd
Adjustable Thermostat Range	60-100
Cooling Airflow (Evaporator)	430 CFM
Exhaust Airflow (Condenser)	430 CFM
Filters	Cooling (evaporator) inlet: 2" x 16" x 20" MERV-11 Exhaust (condenser) inlet: 1" x 12" x 20" MERV-7
Duct Options	Cooling (evaporator): Inlet – 10" Flex-Duct Outlet – 10" Lay-Flat Exhaust (condenser) inlet: Inlet – 10" Flex-Duct Outlet – 14" Lay-Flat or 10" Flex-Duct
Condensate Pump	20' vertical lift
Drain Hose	30'
Power Cord	20' grounded
Construction	Stainless Steel cabinet, (2) 8" recessed wheels
Warranty	Five years; 1st year 100% of Parts and Labor 2nd–5th year 100% of Parts of sealed refrigeration system.

Dimensions

	Machine	Shipping
Width	20.25"	24"
Height	40"	45.25"
Depth	21.375"	25.5"
Weight	142 lb	168 lb

2 Operation

2.1 Transporting

The Phoenix Arctic Max must always be upright when transported by vehicle. It may be tipped onto its handle and back for loading and moving by hand. The Phoenix Arctic Max features a high-impact plastic skid plate which protects the unit while navigating obstacles such as curbs, stairways, and while loading into vehicles.

2.2 Electrical Requirements

The Phoenix Arctic Max plugs into a common grounded outlet on a 15 Amp circuit. It draws 11.8 Amps at 95°F, 60% RH. If used in a wet area, a ground fault interrupter (GFI) is required. If an extension cord is required, it must have a minimum of 14 gauge conductors if 25 feet long or less and 12 gauge conductors if greater than 25 feet long.

2.3 Condensate Removal

The Phoenix Arctic Max is equipped with an internal condensate pump to remove the water that is condensed during dehumidification. This allows the condensate to be pumped 20' with the attached hose. If the condensate must be pumped more than 20 feet above the unit, a second pump must be added to relay the condensate. If the pump fails and the unit must be used before it can be replaced, the condensate can be drained by gravity.

The air inlets and outlets on top, rear, and the side of the unit must be at least 1 foot from walls and other obstructions to air flow. If the humid area is very large, dehumidification can be improved by adding an outlet duct to circulate air to stagnant areas.

2.4 Ducting

A detachable rectangular exhaust collar is supplied to allow 10" round lay-flat duct to be attached to the Phoenix Arctic Max cooling outlet. Lay-flat plastic ducting is available. See accessories on page 6. To attach ducting to a collar, put the plastic duct end through the collar center and roll the duct end outward so that it overlaps the outside of the collar. The duct and collar may then be quickly attached to the Phoenix Arctic Max by snapping the collar over the four screws at the blower outlet.

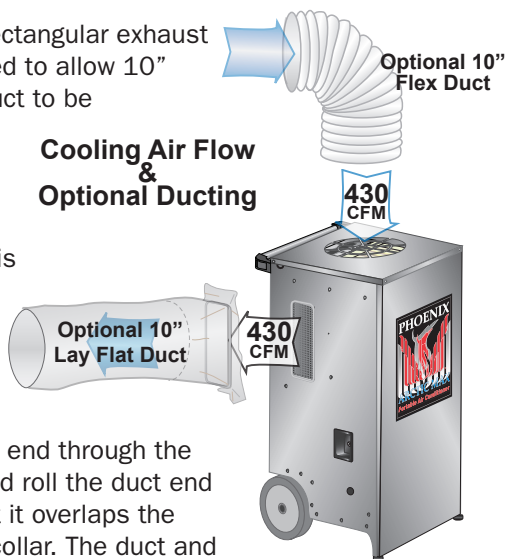

Figure 1

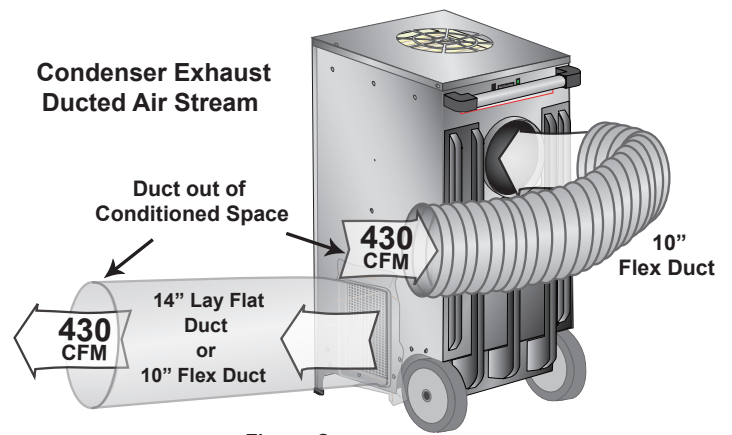

Figure 2

2.5 Power Switch

The power switch (right of hour meter) lights up when the unit is turned on. If the unit is going to run for more than 2 hours in an area below 50°F, the defrost timer should be adjusted to improve performance.

2.6 Purge Switch

Pressing and holding the purge switch (left of hour meter) will cause the condensate pump to run. This pump minimizes the water left in the condensate reservoir prior to moving or storage. Hold the switch in until the flow from the condensate hose stops.

2.7 Hour Meter

The digital hour meter measures the cumulative time that the unit is turned on to tenths of an hour. It stores its total when the unit is unplugged; the previous total will be displayed when the unit is next turned on. It resets to zero after 99,999.9 hours of operation.

2.8 Thermostat Operation

Adjust the cooling thermostat to the desired conditioned space temperature. The thermostat has a range of 60° to 100°F. Turning to "ON" will operate unit continuously regardless of conditioned space temperature.

2.9 Defrost Timer

DRYING TIP: Air's ability to absorb moisture from wet surroundings and the Phoenix Arctic Max ability to remove moisture from that air is greatly improved at higher temperatures. The defrost cycle is automatic and designed for optimum performance above 50°F.

2.10 Low Pressure Control

If the low side refrigerant pressure drops to 15 PSIG, the low pressure control opens and shuts off the compressor and blower. It is an automatically reset control. Its primary function is to prevent damage to the compressor if a leak develops in the refrigeration system. It may also open if the unit is A) used in a cool area (below 50°F) and the defrost timer is not adjusted or B) stored where it is below 40°F and then started. Under these conditions, the unit will restart within several minutes; it may cycle several times until the unit warms up.

3 Maintenance

3.1 Air Filter

The Phoenix Arctic Max is equipped with 2 pleated fabric air filters that must be checked regularly. The cooling air flow filter is a MERV-11 high efficiency filter. The condenser exhaust filter is a MERV-7. Operating the unit with a dirty filter will reduce the dehumidifier's capacity and efficiency and may cause the compressor to cycle off and on unnecessarily on the defrost control.

The filter can generally be vacuumed clean several times before needing replacement. Replacement filters can be ordered from the factory or purchased locally if available.

WARNING

WARNING: DO NOT operate the unit without the filter or with a less effective filter as the heat exchange coils inside the unit could become clogged and require disassembly to clean.

3.2 Storage

There are two issues to consider when the Phoenix Arctic Max is stored between uses and both pertain to the water trapped in the unit: damage caused by freezing or biological growth.

The effect of the trapped water can be greatly reduced if precautions are taken to remove as much as possible before storage.

1. Use the pump purge switch to reduce the water level in the reservoir.
2. Stretch the hose flat to drain it completely.

If the unit will not be exposed to freezing temperatures, an alternative to reduce biological growth is to flush the unit with a bio-fungicide that is approved for use with copper, aluminum and polyethylene. To flush:

1. Run the hose to a drain.
2. Remove the air filter. Remove top and front cover. Slowly pour a quart of the chemical through the evaporator coil fins and drain into the drain pan.
3. Flush coil with water.
4. Hold in the pump purge switch to reduce the water level in the reservoir.

4 Service

WARNING

WARNING: Servicing the Phoenix Arctic Max with its high pressure refrigerant system and high voltage circuitry presents a health hazard which could result in death, serious bodily injury, and/or property damage. Only qualified service people should service this unit.

Do not operate unit without the front panel in place.

4.1 Technical Description

The Phoenix Arctic Max uses a refrigeration system similar to an air conditioner's to remove heat and moisture from incoming air and to add heat to the air that is discharged.

Hot, high pressure refrigerant gas is routed from the compressor to the condenser coil. The refrigerant is cooled and condensed by giving up its heat to the air that is about to be discharged from the unit. The refrigerant liquid then passes through a filter/drier and capillary tubing which cause the refrigerant pressure and temperature to drop. It next enters the evaporator coil where it absorbs heat from the incoming air and evaporates.

The evaporator operates in a flooded condition, which means that all the evaporator tubes contain liquid refrigerant during normal operation. A flooded evaporator should maintain constant pressure and temperature across the entire coil, from inlet to outlet.

The mixture of gas and liquid refrigerant enter the accumulator after leaving the evaporator coil. The accumulator prevents any liquid refrigerant from reaching the compressor. The compressor evacuates the cool refrigerant gas from the accumulator and compresses it to a high pressure and temperature to repeat the process.

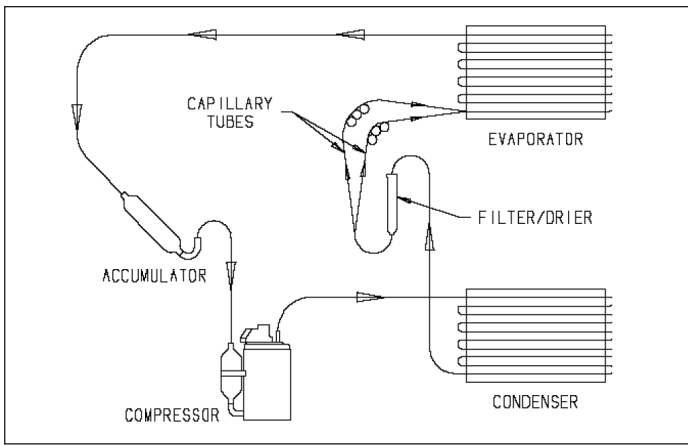

Figure 5: Refrigeration system

4.2 Troubleshooting

No dehumidification, neither blower nor compressor run and power switch does not light when ON.

1. Unit unplugged or no power to outlet.
2. Power switch defective.
3. Loose connection in internal wiring.

No dehumidification, neither blower nor compressor run with power switch ON and lit.

1. Low pressure control open.
2. Power switch defective.
3. Loose connection in internal wiring.
4. Check thermostat setting.

Some dehumidification, blower runs continuously but compressor only runs sporadically.

1. Unit is in defrost cycle.
2. Defrost thermostat defective or loose.
3. Loose connection in compressor circuit.
4. Defective compressor overload.
5. Defective compressor.
6. Defective relay.

No dehumidification, blower runs but compressor does not.

1. Bad connection in compressor circuit.
2. Pump safety switch closed.
3. Defective compressor capacitor.
4. Defective compressor overload.
5. Defective compressor.
6. Defective relay.

Blower does not run. Compressor runs briefly but cycles on and off.

1. Loose connection in blower circuit.
2. Obstruction prevents impeller rotation.
3. Defective blower.

Unit removes some water but not as much as expected.

1. Air temperature and/or humidity have dropped.
2. Humidity meter and/or thermometer used are out of calibration.
3. Unit has entered defrost cycle.
4. Air filter dirty.
5. Defrost timer incorrectly set for conditions.
6. Defective defrost thermostat.
7. Low refrigerant charge.
8. Air leak such as loose cover.
9. Defective compressor.
10. Restrictive exhaust ducting.

Unit runs but does not pump water.

1. Hose kinked or plugged.
2. Pump motor or float switch defective.
3. Pump check valve plugged.
4. Bad connection in pump circuit.
5. Hose disconnected internally.

Unit pumps water automatically but not when purge switch is pushed.

1. Bad connection in purge switch circuit.
2. Defective purge switch.

Evaporator coil frosted continuously, low dehumidifying capacity.

1. Defrost thermostat loose or defective.
2. Defrost timer incorrectly set or defective.
3. Low refrigerant charge.
4. Dirty air filter or air flow restricted.

Compressor runs with power switch OFF.

1. Defective relay.
2. Defective power switch.

4.3 Blower Replacement

The motorized impeller has a PSC motor and internal thermal overload protection. If defective, the complete assembly must be replaced.

1. Unplug the power cord.
2. Remove the top and cabinet front (6 screws).
3. Disconnect the impeller leads.
4. Remove four screws holding the impeller to the impeller brackets.
5. Remove impeller. Use care to avoid hooking wiring, tubing or electrical components.
6. Reassemble with the new impeller in the above procedure reversed.

4.4 Defrost Thermostat and Timer

The defrost thermostat is attached to the refrigerant suction tube between the accumulator and compressor. If the low side refrigerant temperature drops due to excessive frost formation on the evaporator coil, the thermostat opens. The compressor is then cycled off and on by the defrost timer. The blower will continue to run, causing air to flow through the evaporator coil and melt the ice when the compressor is off. When the air temperature and/or humidity increase, the evaporator temperature will rise and the thermostat will close to end the defrost cycle.

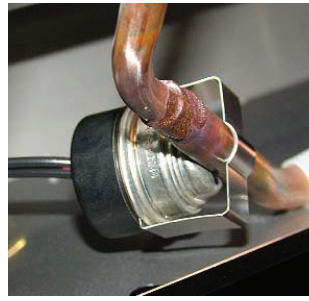

Figure 6: Defrost thermostat

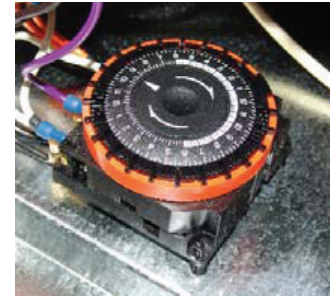

Figure 7: Defrost timer

4.5 Condensate Pump

Condensate is automatically pumped when the water level in the pump's reservoir rises to close the float switch or if the pump purge switch is held in.

To replace the condensate pump:

1. Remove the metal strap holding the pump by loosening the 2 screws holding it in place.
2. Disconnect the leads.
3. Installation is the reverse of above, but check that the plastic inlet and outlet hoses do not rub against copper refrigerant tubes.

4.6 Gravity Drain Option

If the condensate pump fails and cannot be replaced immediately, the Phoenix Arctic Max can be used by draining by gravity.

1. Unplug the unit and remove the front cover.
2. Push the plastic plug on the left side out from inside the unit.
3. Locate the heavy vinyl hose that connects the drain pan to the condensate pump. Pull the end out of the pump.
4. Push that end of the vinyl hose through the hole in the left side.

5. Connect a garden hose and run it to a drain. Keep the hose as flat to the floor as possible to avoid air pockets that would hinder draining. Placing the unit on something above the floor will also improve draining.

4.7 Relay

The contacts of the single pole, single throw relay complete the power circuit to the compressor. The contacts are closed when power is provided to the relay coil via the control circuit. The control circuit includes the power switch, low pressure control, defrost thermostat and timer.

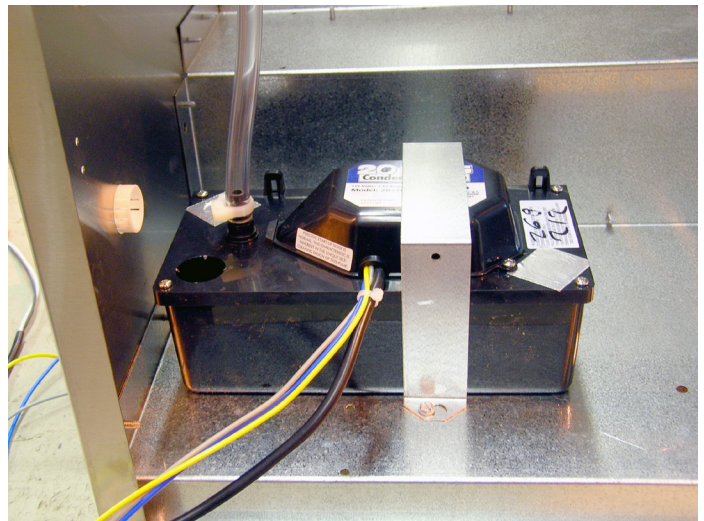

Figure 8: Condensate pump

5 Options and Accessories

- | | |
|---------|---|
| 4021475 | Air Filter, Pleated, 2" x 16" x 20"
MERV-11 |
| 4026884 | Air Filter, 1" x 12" x 20"
MERV-7 |
| 4022126 | Insulated Flex Duct, 10"
10" x 25' Metalized Polyester |
| 4026969 | Flex Duct, 10", Metalized Polyester, 25' |
| 4024935 | Lay-Flat Duct, 10" Round x 250' Roll |
| 4024936 | Lay-Flat Duct, 14" Round x 250' Roll |

6 Wiring Diagram

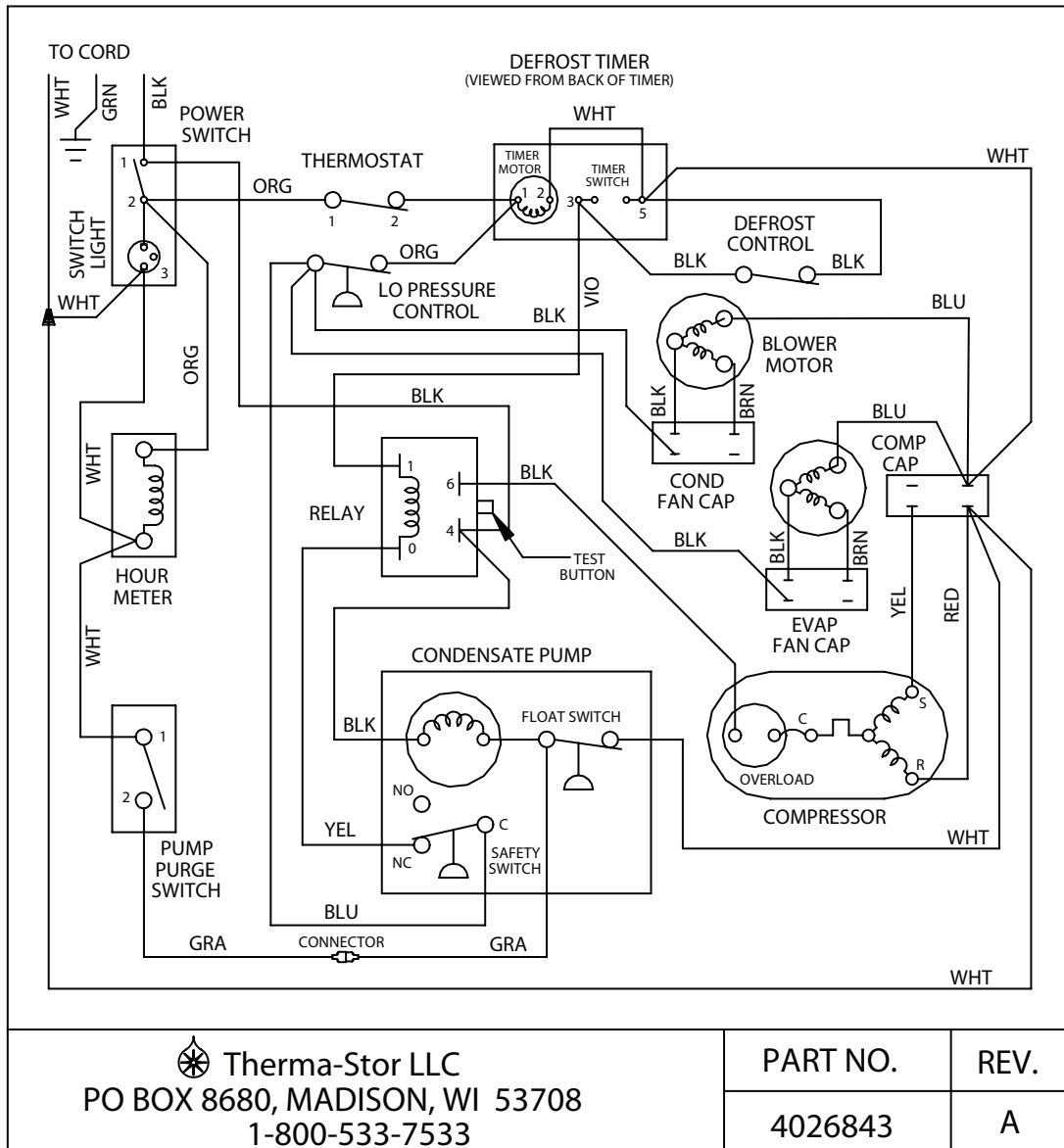
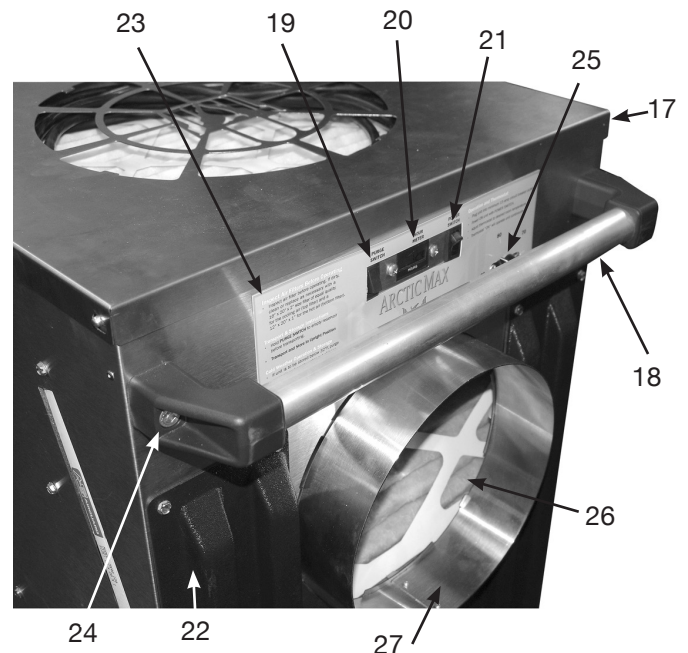
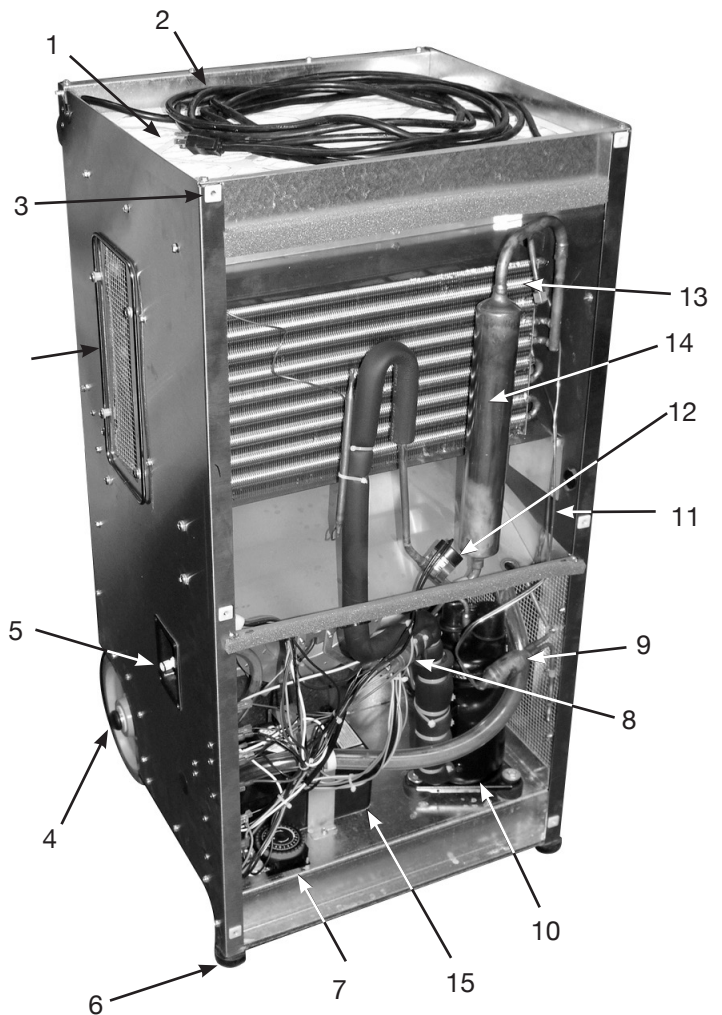

Figure 8: Wiring diagram

8 Service Parts

Item	Description	Qty	Part No.
1	Filter, Cooling, 2 x 16 x 20	1	4021475
2	Cord	1	4026890
3	Front Panel Retaining Nut, 1/4-20	6	4023362
4	Wheel, 8"	2	4025676
	Wheel Hub Cap	2	4024816
	Retaining Ring	2	4025454
	Hub Cap Retaining Washer	2	4025295
5	Coupling Body, 1/4 Tube	1	4024910
6	Foot	2	4024073
7	Defrost Timer	1	4021823
8	Low Pressure Control	1	4029508
9	Filter/Drier	1	4029510
10	Compressor	1	4029190
	Overload, Compressor	1	4029714
	Capillary Tubes	3	4030087
12	Defrost Thermostat	1	4025741
	Defrost Control Mounting Clip	1	4021648
13	Evaporator Coil	1	4033925-02
14	Accumulator	1	4022254
15	Condensate Pump	1	4034495
16	10" Wire Duct Collar (Cooling)	1	4024078
17	Top	1	4029267
18	Handle Assembly	1	4026094
19	Pump Purge Switch	1	4021796
20	Hour Meter	1	4028795
21	Power Switch	1	4021822
22	Skid Plate	1	4026839
23	Instruction Label	1	4026857
24	Handle Screw (M10-1.5 x 35)	2	1177792
	Handle Nut (M10-1.5)	2	1223780
25	Thermostat	1	4026885
26	Filter, Exhaust, 1 x 12 x 20	1	4026884
27	10" Duct Ring	1	4022611
Items listed below are not shown			
	Drain Hose (.25 ID x 33' long)	1	4024916
	Front Panel Screw, 1/4-20 x 1/2	1	1096006
	Condenser Coil	1	4028226
	Motorized Impeller Fan	2	4025076
	Relay, Compressor	1	1970010
	Run Capacitor, Comp. 45 µF	1	4033032-05
	Run Capacitor, Fan, 15 µF	2	4033031-07
	14" Wire Duct Collar	1	4024079
	14" to 10" Duct Adapter	1	4026845



Specifications subject to change without notice.

Phoenix Arctic Max Limited Warranty

Warrantor:

Therma-Stor LLC
4201 Lien Rd
Madison, WI 53704
Telephone: 1-800-533-7533

Who Is Covered: This warranty extends only to the original end-user of the Phoenix Arctic Max, and may not be assigned or transferred.

Year One: Therma-Stor LLC warrants that, for one (1) year the Phoenix Arctic Max will operate free from any defects in materials and workmanship, or Therma-Stor LLC will, at its option, repair or replace the defective part(s), free of any charge.

Years Two Through Five: Therma-Stor LLC further warrants that for a period of five (5) years, the condenser, evaporator, and compressor of the Phoenix Arctic Max will operate free of any defects in material or workmanship, or Therma-Stor LLC, at its option, will repair or replace the defective part(s), provided that all labor and transportation charges for the part(s) shall be borne by the end-user.

End-User Responsibilities: Warranty service must be performed by a Servicer authorized by Therma-Stor LLC. If the end-user is unable to locate or obtain warranty service from an authorized Servicer, he should call Therma-Stor LLC at the above number and ask for the Therma-Stor Service Department, which will then arrange for covered warranty service. Warranty service will be performed during normal working hours.

The end-user must present proof of purchase (lease) upon request, by use of the warranty card or other reasonable and reliable means. The end user is responsible for normal care. This warranty does not cover any defect, malfunction, etc. resulting from misuse, abuse, lack of normal care, corrosion, freezing, tampering, modification, unauthorized or improper repair or installation, accident, acts of nature or any other cause beyond Therma-Stor LLC's reasonable control.

Limitation and Exclusions: If any Phoenix Arctic Max part is repaired or replaced, the new part shall be warranted for only the remainder of the original warranty period applicable thereto (but all warranty periods will be extended by the period of time, if any, that the Phoenix Arctic Max is out of service while awaiting covered warranty service).

UPON THE EXPIRATION OF THE WRITTEN WARRANTY APPLICABLE TO THE PHOENIX ARCTIC MAX OR ANY PART THEREOF, ALL OTHER WARRANTIES IMPLIED BY LAW, INCLUDING MERCHANTABILITY AND FITNESS FOR A PARTICULAR PURPOSE, SHALL ALSO EXPIRE.

ALL WARRANTIES MADE BY THERMA-STOR LLC ARE SET FORTH HEREIN, AND NO CLAIM MAY BE MADE AGAINST THERMA-STOR LLC BASED ON ANY ORAL WARRANTY. IN NO EVENT SHALL THERMA-STOR LLC, IN CONNECTION WITH THE SALE, INSTALLATION, USE, REPAIR OR REPLACEMENT OF ANY Phoenix Arctic Max DEHUMIDIFIER OR PART THEREOF BE LIABLE UNDER ANY LEGAL THEORY FOR ANY SPECIAL, INDIRECT OR CONSEQUENTIAL DAMAGES INCLUDING WITHOUT LIMITATION WATER DAMAGE (THE END-USER SHOULD TAKE PRECAUTIONS AGAINST SAME), LOST PROFITS, DELAY, OR LOSS OF USE OR DAMAGE TO ANY REAL OR PERSONAL PROPERTY.

Some states do not allow limitations on how long an implied warranty lasts, and some do not allow the exclusion or limitation of incidental or consequential damages, so one or both of these limitation may not apply to you.

Legal Rights: This warranty gives you specific legal rights, and you may also have other rights which vary from state to state.

